

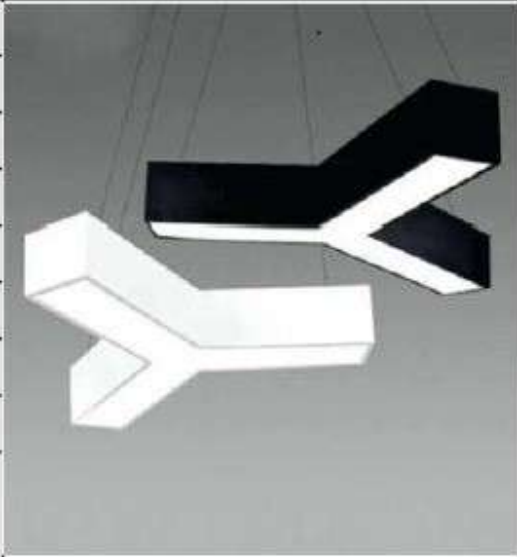

1	Drum / Moon Pendant Light	CT-CW / WW / NW		300mm	Standard
		Product Type - Drum / Moon		Branded Fulham /Osram/Bag Etc	
		MATERIAL ALLUMINUM		450mm	Standard
		Input Voltage 210 - 230 Volt (V)		Branded Fulham /Osram/Bag Etc	
		Lamp Power 24W Watt (W)		600mm	Standard
		Size 50 X 50 MM		Branded Fulham /Osram/Bag Etc	
		Dimension (L*W*H) 50 X 50 MM		900mm	Standard
		Body colour - White / Black		Branded Fulham /Osram/Bag Etc	
			<b>Ring / Donut Pendant Light</b>		
2	Ring / Donut Pendant Light	CT - CW / WW / NW		300mm	Standard
		Product Type - Ring / Donut		Branded Fulham /Osram/Bag Etc	
		Material Aluminum / MS / SS		450mm	Standard
		Input Voltage 210 - 230 Volt (V)		Branded Fulham /Osram/Bag Etc	
		Lamp Power 24 W Watt (W)		600mm	Standard
		Size 50 X 50 MM		Branded Fulham /Osram/Bag Etc	
		Dimension (L*W*H) 50 X 50 MM		750mm	Standard
		Body colour - White / Black		Branded Fulham /Osram/Bag Etc	
				900mm	Standard
	Branded Fulham /Osram/Bag Etc				

3	Triangle Linear Light	CT - CW / WW / NW		300mm	Standard
		Product Type - Ring / Donet		Branded Fulham /Osram/Bag Etc	
		Material Aluminum / MS / SS		450mm	Standard
		Input Voltage 210 - 230 Volt (V)		Branded Fulham /Osram/Bag Etc	
		Lamp Power 24 W Watt (W)		600mm	Standard
		Size 50 X 50 MM		Branded Fulham /Osram/Bag Etc	
		Dimension (L*W*H) 50 X 50 MM		900mm	Standard
		Body colour - White / Black		Branded Fulham /Osram/Bag Etc	
			<b>Triangle Drum Light</b>		
4	Triangle Drum Light	CT - CW / WW / NW		300mm	Standard
		Product Type - Ring / Donet		Branded Fulham /Osram/Bag Etc	
		Material Aluminum / MS / SS		450mm	Standard
		Input Voltage 210 - 230 Volt (V)		Branded Fulham /Osram/Bag Etc	
		Lamp Power 24 W Watt (W)		600mm	Standard
		Size 50 X 50 MM		Branded Fulham /Osram/Bag Etc	
		Dimension (L*W*H) 50 X 50 MM		750mm	Standard
		Body colour - White / Black		Branded Fulham /Osram/Bag Etc	
				900mm	Standard
	Branded Fulham /Osram/Bag Etc				

6	Hexa Drum Light	CT-CW / WW / NW		300mm	Standard
		Product Type - Ring/Donut			Branded Fulham /Osram/Bag Etc
		Material - ALLUMINUM / MS / SS		450mm	Standard
		Input Voltage 210 - 230 Volt (V)			Branded Fulham /Osram/Bag Etc
		Lamp Power 24W Watt (W)		600mm	Standard
		Size 50 X 50 MM			Branded Fulham /Osram/Bag Etc
		Dimension (L*W*H) 50 X 50 MM		750mm	Standard
		Body colour - White / Black			Branded Fulham /Osram/Bag Etc
				900mm	Standard
		Branded Fulham /Osram/Bag Etc			

**Y Shape Light**

7	Y Shape Light	CT-CW / WW / NW		300mm	Standard
		Product Type - Ring/Donut			Branded Fulham /Osram/Bag Etc
		Material - ALLUMINUM / MS / SS		600mm	Standard
		Input Voltage 210 - 230 Volt (V)			Branded Fulham /Osram/Bag Etc
		Lamp Power 24W Watt (W)		900mm	Standard
		Size 50 X 50 MM			Branded Fulham /Osram/Bag Etc
		Dimension (L*W*H) 53 X 70 MM 35 X 70		1200mm	Standard
		Body colour - White / Black			Branded Fulham /Osram/Bag Etc

5	Hexa Linear Light	CT - CW / WW / NW		300mm	Standard
		Product Type - Ring / Donut			Branded Fulham /Osram/Bag Etc
		Material Aluminum / MS / SS		450mm	Standard
		Input Voltage 210 - 230 Volt (V)			Branded Fulham /Osram/Bag Etc
		Lamp Power 24 W Watt (W)		600mm	Standard
		Size 50 X 50 MM			Branded Fulham /Osram/Bag Etc
		Dimension (L*W*H) 50 X 50 MM		900mm	Standard
		Body colour - White / Black			Branded Fulham /Osram/Bag Etc